

## BSTHF28S05F

### DC/DC Converter

### Data Sheet

#### I. Product Introduction

BSTHF28S05F is a single-channel 5V/3A, 15W output DC/DC converter. Manufactured using thick-film hybrid integrated circuit technology, it features a fully sealed metal housing and is designed for use in DC power supply systems to achieve DC voltage conversion.

#### II. Product Performance Indicators

The electrical characteristics shall be as specified in Table 1.

Table 1. Electrical characteristics

CHARACTERISTIC	SYMBOL	CONDITION (UNLESS OTHERWISE SPECIFIED, - 55°C ≤ T <sub>c</sub> ≤ 125°C, V <sub>I</sub> = 28V ± 0.5V, C <sub>L</sub> = 0.1μF)	GROUP A GROUPING	LIMIT VALUE		UNIT
				MINIMUM	MAXIMUM	
Output voltage	V <sub>O</sub>	V <sub>I</sub> = 15V ~ 50V, full load	1	4.93	5.07	V
			2,3	4.92	5.08	
Output current	I <sub>O</sub>	V <sub>I</sub> = 15V ~ 50V	1,2,3	-	3.0	A
Output ripple voltage (peak-to-peak)	V <sub>RIP</sub>	Full load, BW ≤ 20MHz	1	-	40	mV
			2,3	-	60	
Voltage regulation	S <sub>V</sub>	V <sub>I</sub> = 15V ~ 50V, full load	1	-	20	mV
			2,3	-	50	
Current regulation	S <sub>I</sub>	Empty → Fully loaded	1,2,3	-	50	mV
Input current	I <sub>I</sub>	No load, prohibit terminal connected to input ground terminal	1,2,3	-	6	mA
		No load, open circuit prohibited		-	60	
Input ripple current <sup>b</sup> (peak-to-peak)	I <sub>RIP</sub>	BW ≤ 20MHz, full load	1	-	80	mA
			2,3	-	100	
efficiency	η	fully loaded	1	72	-	%
			2,3	70	-	
Startup threshold voltage <sup>b</sup>	V <sub>ION</sub>	Full load, input voltage from 11V → 28V	1,2,3	12.0	14.8	V

CHARACTERISTIC	SYMBOL	CONDITION (UNLESS OTHERWISE SPECIFIED, - 55°C ≤ T <sub>C</sub> ≤ 125°C, V <sub>I</sub> = 28V ± 0.5V, C <sub>L</sub> = 0.1μF)	GROUP A GROUPING	LIMIT VALUE		UNIT
				MINIMUM	MAXIMUM	
Undervoltage threshold voltage <sup>b</sup>	V <sub>IOFF</sub>	Full load, input voltage from 28V to 11V	1,2,3	11.0	14.5	V
Insulation resistance	R <sub>I</sub>	DC between the input and output or between any lead (except pins 5 and 6) and the case. T <sub>A</sub> = 25 °C	1	100	-	MΩ
Short-circuit power consumption	P <sub>D</sub>	Short Circuit	1,2,3	-	8	W
Capacitive load a	C <sub>L</sub>	Full load, T <sub>A</sub> = 25 °C	4	-	1000	μF
Switching frequency	f <sub>s</sub>	fully loaded	4,5,6	350	500	kHz
bc (peak value) during load transient	V <sub>LT</sub>	50% load → full load or full load → 50% load	4,5,6	-	600	mV
Output voltage recovery time bcd during load transients	t <sub>LT</sub>	50% load → full load or full load → 50% load	4,5,6	-	600	μS
Output voltage change (peak value) when input voltage changes transiently	V <sub>VT</sub>	Input voltage V <sub>I</sub> : 16V → 40V, full load	4,5,6	-	800	mV
Output voltage recovery time bde when input voltage transient	t <sub>VT</sub>	Input voltage V <sub>I</sub> : 16V → 40V, full load	4,5,6	-	700	μS
Startup delay f	t <sub>d</sub>	Input voltage V <sub>I</sub> : 0V → 28V, full load	4	-	20	mS
			5,6	-	25	
Start-up overshoot (peak)	V <sub>TO</sub>	Input voltage V <sub>I</sub> : 0V → 28V, full load	4,5,6	-	25	mV

a. Capacitive load can be any value between 0 and the maximum limit value without affecting the DC parameters;  
b. This parameter is guaranteed by design and is only tested during the initial quality consistency inspection or when the design or process is changed;  
c. The load transition time should be greater than 10 μs;  
d. Recovery time refers to the time from the start of the jump until the output voltage returns to the corresponding stable value within ±1%;  
e. The transition time of the input voltage should be greater than 10 μs;  
f. can be calculated from the start of the power supply jump or from the disconnection of the grounded inhibit terminal.

### III. Appearance and Size

The outer shape of the housing shall be as specified in Figure 1.

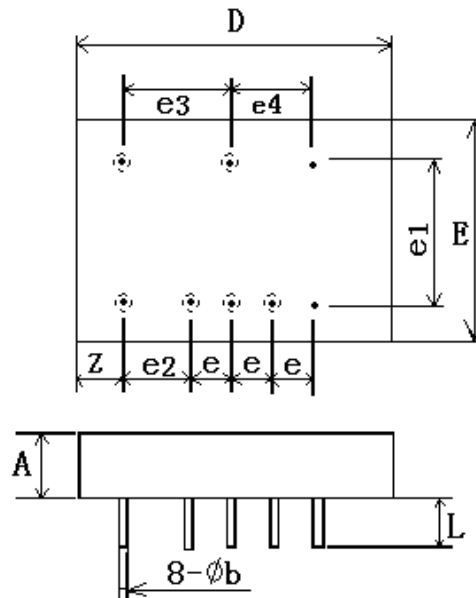

Figure 1a. BSTHF28S05 dimensions

Table 2

Unit is millimeter

NUMBER	NUMERICAL		
	MINIMUM	NOMINAL	MAXIMUM
A	—	—	8.50
$\phi b$	0.71	—	0.81
D	—	—	37.13
Z	—	—	5.41
e	—	5.08	—
e <sub>1</sub>	—	20.32	—
e <sub>2</sub>	—	7.62	—
e <sub>3</sub>	—	12.70	—
e <sub>4</sub>	—	10.16	—
E	—	—	28.74
L	6.10	—	6.60

**Note:**

1. For tolerances not specified, the M level in GB/T 1804-2000 shall apply;
2. The interchangeability of dimensions e, e<sub>1</sub> ~ e<sub>4</sub> is ensured by the manufacture and inspection of the housing and is not required for assessment in this specification.

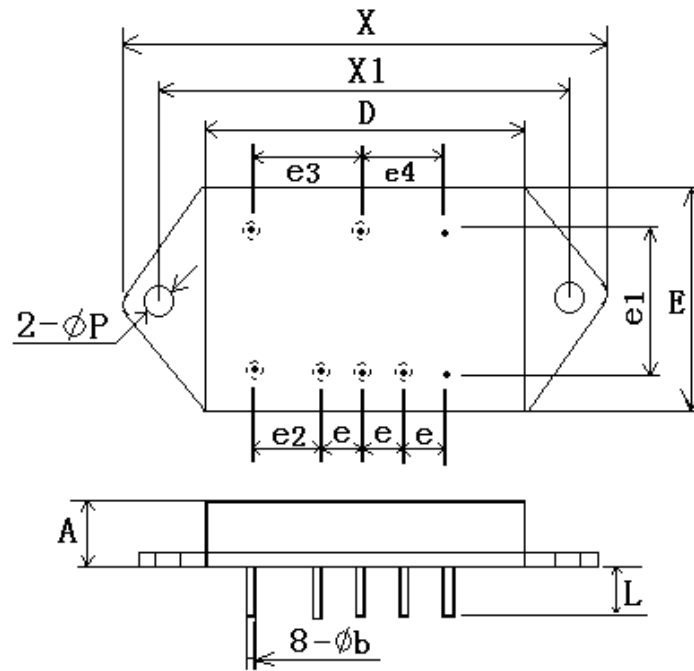

Figure 1b. BSTHF28S05F dimensions

Table 3

Unit is millimeter

NUMBER	NUMERICAL		
	MINIMUM	NOMINAL	MAXIMUM
A	—	—	8.50
φb	0.71	—	0.81
e	—	5.08	—
e <sub>1</sub>	—	20.32	—
e <sub>2</sub>	—	7.62	—
e <sub>3</sub>	—	12.70	—
e <sub>4</sub>	—	10.16	—
E	—	—	28.74
L	6.10	—	6.60
φP	—	3.30	—
X	—	—	50.80
X <sub>1</sub>	—	43.95	—
D	—	—	37.13

Note:

1. For tolerances not specified, the M level in GB/T 1804-2000 shall apply;
2. The interchangeability of dimensions e, e<sub>1</sub> ~ e<sub>4</sub> is ensured by the manufacture and inspection of the housing and is not required for assessment in this specification.

## IV. Pin Function Description

The terminal arrangement should comply with the requirements of Figure 2.

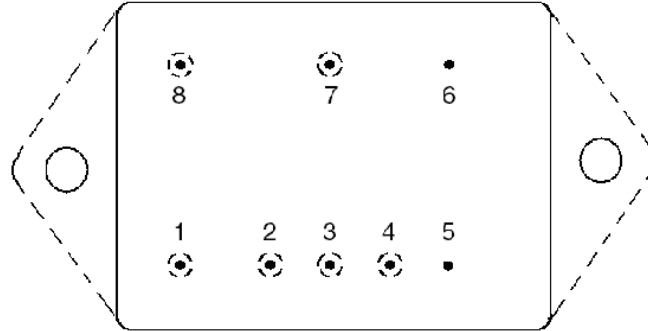

Figure 2. Terminal arrangement (top view)

Table 4

PIN NUMBER	SYMBOL	FUNCTION	PIN NUMBER	SYMBOL	FUNCTION
1	INH	Inhibit	5	GND <sub>C</sub>	Case ground
2	NC	No connection	6	GND <sub>C</sub>	Case ground
3	GND	Output common	7	GND <sub>IN</sub>	Input common
4	V <sub>O</sub>	Positive output	8	V <sub>IN</sub>	Positive input

## V. Typical Application Diagram

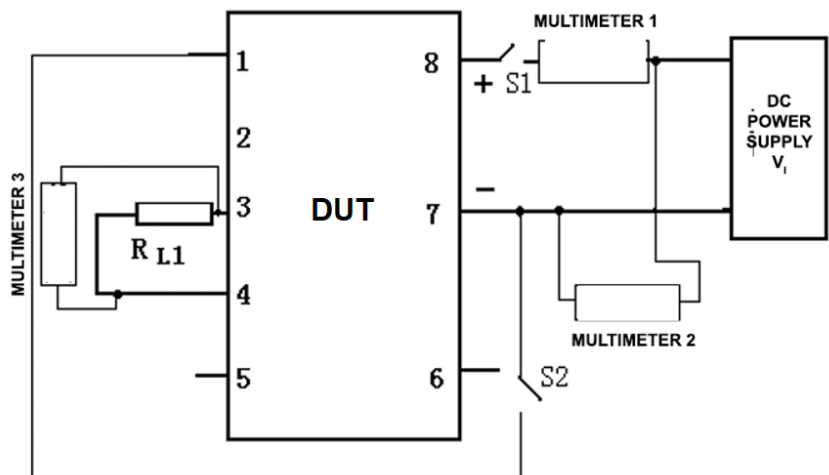

Figure 3. Typical application diagram

## VI. Application Description

Instructions for the Disable Pin:

When the disable function is not in use, leave the disable pin unconnected.

When the disable function is in use, connect it to input ground (low level disable).

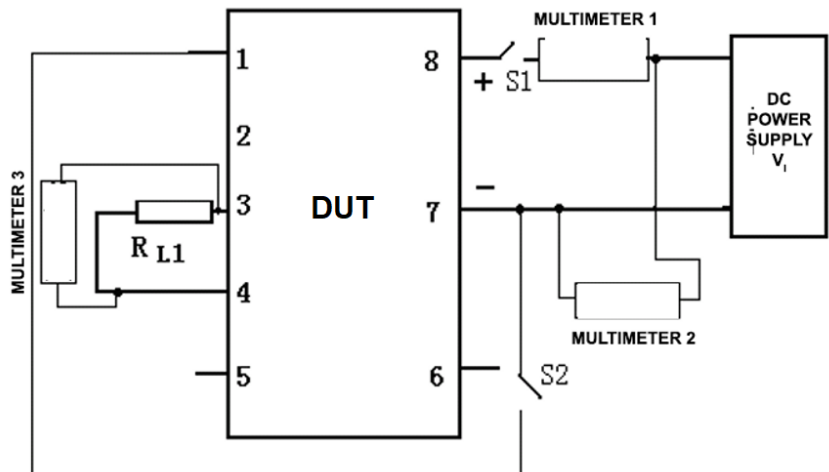

Figure 4. Schematic diagram of prohibited terminal wiring

## VII. Precautions

Prevent product collision.

There are glass insulators between the lead pins (except the shell pins) and the metal shell. Bending or collision of the lead pins is prohibited. Products with flanges should be fixed to the structural parts before welding the lead pins.

Do not connect the power supply polarity in reverse and pay attention to the input voltage range.

A heat sink or other heat dissipation measures should be installed to ensure that the shell temperature is lower than the maximum operating temperature specified for the product. The operating temperature range of the product is:  $-55^{\circ}\text{C} \leq T_{\text{C}} \leq 125^{\circ}\text{C}$ .

Pay attention to the "1" pin mark and install the board and solder according to the correct installation direction. The pin close to the " $\Delta$ " mark on the surface of the product shell is pin 1, and the circular concave point at the bottom of the product shell is the identification mark of pin 1.

The product cannot be assembled by reflow soldering, reflow soldering or wave soldering. It is recommended to use manual soldering for the pins. The lead wire resistance soldering temperature is lower than 300°C and the soldering time does not exceed 10s.