

## BSTCH28D15

### DC/DC Converter

### Data Sheet v.1.0

## I. Product Features

BSTCH28D15 DC/DC converter is manufactured using thick-film hybrid integrated circuit technology and features a fully sealed metal casing. This product offers dual 15V isolated outputs. It is compact, has low output ripple, excellent output stability, strong transient load capacity, and is isolated between input and output, making it suitable for operation over a full temperature range.

## II. Product Performance Indicators

Table 1

CHARACTERISTIC	SYMBOL	CONDITION (UNLESS OTHERWISE SPECIFIED) -55°C ≤ T <sub>c</sub> ≤ 125°C V <sub>i</sub> = 28V±0.5 V, C <sub>L</sub> = 0.1μF)	GROUP A GROUPING	LIMIT VALUE		UNIT
				MINIMUM	MAXIMUM	
Output voltage	V <sub>O1</sub>	V <sub>i</sub> = 12V ~ 50V, I <sub>O1</sub> = I <sub>O2</sub> = 50mA	1	14.85	15.15	V
			2,3	14.40	15.60	
	V <sub>O2</sub>		1	-15.15	-14.85	
			2,3	-15.60	-14.40	
Output current	I <sub>O1</sub>	V <sub>i</sub> = 12V ~ 50V	1,2,3	-	50	mA
	I <sub>O2</sub>					
Output ripple voltage (Peak-to-peak value)	V <sub>RIP1</sub>	I <sub>O1</sub> = I <sub>O2</sub> = 50mA, BW ≤ 20MHz	1,2,3	-	100	mV
	V <sub>RIP2</sub>					
Voltage regulation	S <sub>V1</sub>	V <sub>i</sub> = 12V → 50V, I <sub>O1</sub> = I <sub>O2</sub> = 50mA	1,2,3	-	50	mV
	S <sub>V2</sub>					
Current regulation	S <sub>I1</sub>	I <sub>O1</sub> = I <sub>O2</sub> = 0mA → 50mA, both outputs change simultaneously.	1,2,3	-	50	mV
	S <sub>I2</sub>					
Input current	I <sub>i</sub>	No load, prohibit the connection of the terminal to the input ground terminal.	1,2,3	-	10	mA
		No load, no open circuit allowed		-	20	
Input ripple current (peak-to-peak value)	I <sub>RIP</sub>	BW ≤ 20MHz, I <sub>O1</sub> = I <sub>O2</sub> = 50mA	1	-	30	mA
			2,3	-	40	

CHARACTERISTIC	SYMBOL	CONDITION (UNLESS OTHERWISE SPECIFIED) -55°C ≤ T <sub>c</sub> ≤ 125°C V <sub>i</sub> = 28V±0.5 V, C <sub>L</sub> = 0.1μF)	GROUP A GROUPING	LIMIT VALUE		UNIT
				MINIMUM	MAXIMUM	
Efficiency	η	I <sub>O1</sub> = I <sub>O2</sub> = 50mA	1	72	-	%
			2,3	67	-	
Insulation resistance	R <sub>i</sub>	Apply 500VDC between the input/output terminals or between any of the leads (except for terminal 5) and the casing; T <sub>A</sub> = 25°C	1	100	-	MΩ
Short-circuit power consumption	P <sub>D</sub>	Output short circuit	1,2,3	-	4.5	W
Startup threshold	V <sub>ION</sub>	Input voltage from 0V → 12V	1,2,3	6.5	11.8	V
capacitive load <sup>a</sup>	C <sub>L1</sub>	No effect on DC parameters, T <sub>A</sub> = 25°C	4	-	200	μF
	C <sub>L2</sub>					
Switching frequency	f <sub>s</sub>	I <sub>O1</sub> = I <sub>O2</sub> = 50mA	4,5,6	325	475	kHz
Output voltage change (peak value) during load transients <sup>bc</sup>	V <sub>LT1</sub>	50% load → Full load or Full load → 50% load Each output has a balanced load.	4,5,6	-300	300	mV
	V <sub>LT2</sub>					
Recovery time of output voltage during load transients <sup>bcd</sup>	t <sub>LT1</sub>	50% load → Full load or Full load → 50% load Each output has a balanced load.	4	-	400	μs
	t <sub>LT2</sub>		5,6	-	800	
Output voltage change (peak value) during input voltage transients <sup>be</sup>	V <sub>VT</sub>	Input voltage V <sub>i</sub> : 12V → 50V, I <sub>O1</sub> = I <sub>O2</sub> = 50mA	4,5,6	-600	600	mV
Output voltage recovery time during input voltage transient <sup>bde</sup>	t <sub>VT</sub>	Input voltage V <sub>i</sub> : 12V → 50V, I <sub>O1</sub> = I <sub>O2</sub> = 50mA	4	-	600	μs
			5,6	-	1200	
Start-up overshoot (peak value)	V <sub>TO1</sub>	Input voltage V <sub>i</sub> : 0V → 28V, I <sub>O1</sub> = I <sub>O2</sub> = 50mA	4,5,6	-	50	mV
	V <sub>TO2</sub>					
Startup delay <sup>f</sup>	t <sub>d1</sub>	Input voltage V <sub>i</sub> : 0V → 28V, I <sub>O1</sub> = I <sub>O2</sub> = 50mA	4,5,6	-	20	ms
	t <sub>d2</sub>					

- a. Capacitive load can be any value from 0 to the maximum limit, without affecting DC parameters;
- b. This parameter is guaranteed by design and is only tested during the initial quality conformity inspection and design or process changes.
- c. The jump time of the load should be greater than 10μs;
- d. The recovery time refers to the time from the start of the jump until the output voltage returns to within ±1% of the corresponding stable value;
- e. The jump time of the input voltage should be greater than 10μs;
- f. The start-up delay time can be calculated either from the power supply transition or from when the grounded prohibition terminal is disconnected.

### III. Shape and Dimensions

The external dimensions shall conform to the provisions of GB/T15138 and Figure 1.

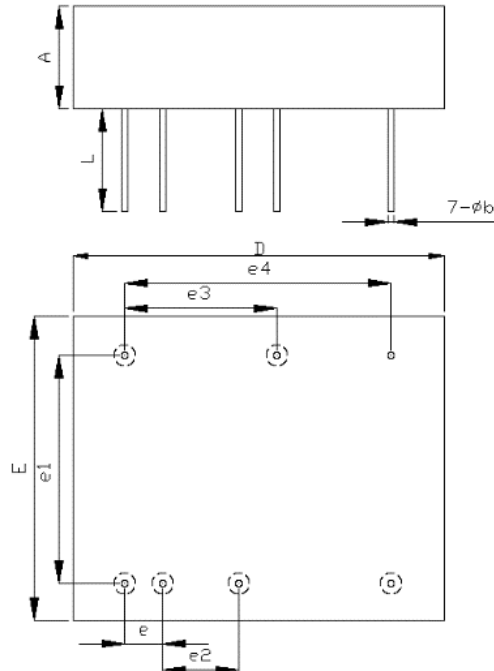

Figure 1. External dimensions of BSTCH28D15

Table 2

The unit is millimeters

RULER INCH TALISMAN NUMBER	NUMERICAL VALUES		
	MINIMUM	NOMINAL	MAXIMUM
A	-	-	6.90
φb	0.40	-	0.50
D	-	-	24.87
E	-	-	20.42
e	-	2.54	-
e <sub>1</sub>	-	15.24	-
e <sub>2</sub>	-	5.08	-
e <sub>3</sub>	-	10.16	-
e <sub>4</sub>	-	17.78	-
L	6.61	-	7.11

Note:  
1. Unspecified tolerances shall comply with GB/T m-level execution in 1804-2000.

## IV. Description of Lead-Out Pin Functions

The arrangement of the leads should conform to the specifications in Figure 2.

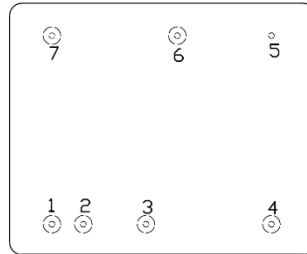

Figure 2. Lead-out terminal arrangement diagram

Table 3

Lead-out serial number	Symbol	Function	Lead-out serial number	Symbol	Function
1	$V_i$	Input positive	5	CASE	Case
2	$GND_i$	Input common	6	$V_{o-}$	Output negative
3	$V_o$	Output positive	7	INH	Inhibit
4	$GND_o$	Output common	-	-	-

## V. Test Schematic Diagram

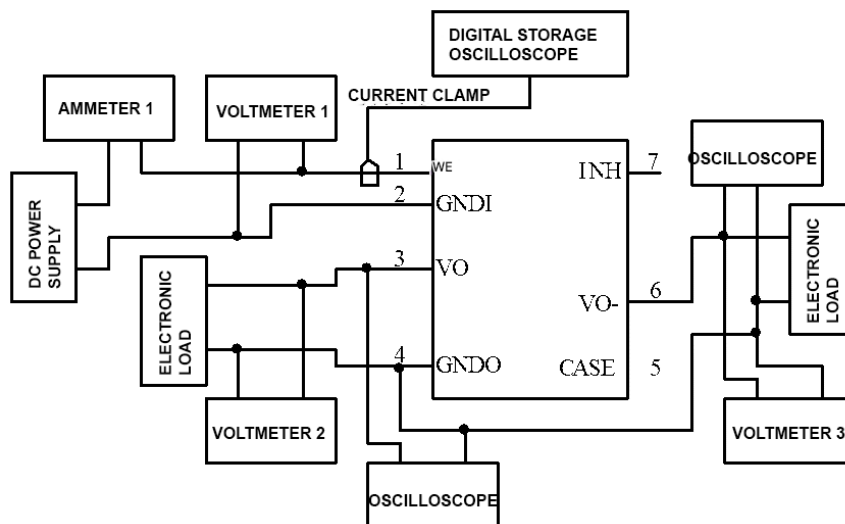

Figure 3. Test principle block diagram

Ammeter 1 measures its input current  $I_{in}$ , voltmeter 1 measures its input voltage  $V_{in}$ , voltmeter 2 measures its output +15V voltage  $V_{O1}$ , and voltmeter 3 measures its output -15V voltage  $V_{O1}$ . An electronic load with an output current of 50mA is used, and its output current is measured. (If a resistive load is used, two digital multimeters need to be added to the output terminal to

measure its output current. The resistance of the load resistor is 300  $\Omega$ . An oscilloscope measures the output ripple voltage; to avoid interference, the ripple voltage test should be performed using a proximity measurement method as much as possible.

## VI. Application

Power the corresponding modules in the system.

## VII. Precautions

The following are precautions for hybrid circuits.

- Prevent the circuit from being bumped;
- Protect the glass insulators of the pins; do not bend or bump the pins;
- Trim any excess pin length before installation.